

PRELIMINARY

PM75CLA060

FLAT-BASE TYPE
INSULATED PACKAGE

Notice : This is not a final specification. Some parametric limits are subject to change.

PM75CLA060

Pre.	<i>↑ Marumo</i>	Rev.	
Apr.	<i>(h. Tabata 30.Aug.'02)</i>		

Feature

- a) Adopting new 5th generation IGBT(CSTBT) chip, which performance is improved by 1μm fine rule process.
For example, typical $V_{ce(sat)}=1.5V @T_j=125^{\circ}C$
- b) Adopt the over-temperature conservation by T_j detection of CSTBT chip, and error output is possible from upper arm and a lower arm of IPM at all each protection.
- c) New small package
Reduce the package size by 32%, thickness by 22% from S-DASH series.

OUTLINE DRAWING Dimensions in mm

See Page 7

- 3φ 75A, 600V Current-sense IGBT type inverter
- Monolithic gate drive & protection logic
- Detection, protection & status indication circuits for, short-circuit, over-temperature & under-voltage (P-Fo available from upper arm devices)
- Acoustic noise-less 5.5kW/7.5kW class inverter application

APPLICATION : General purpose inverter, servo drives and other motor controls

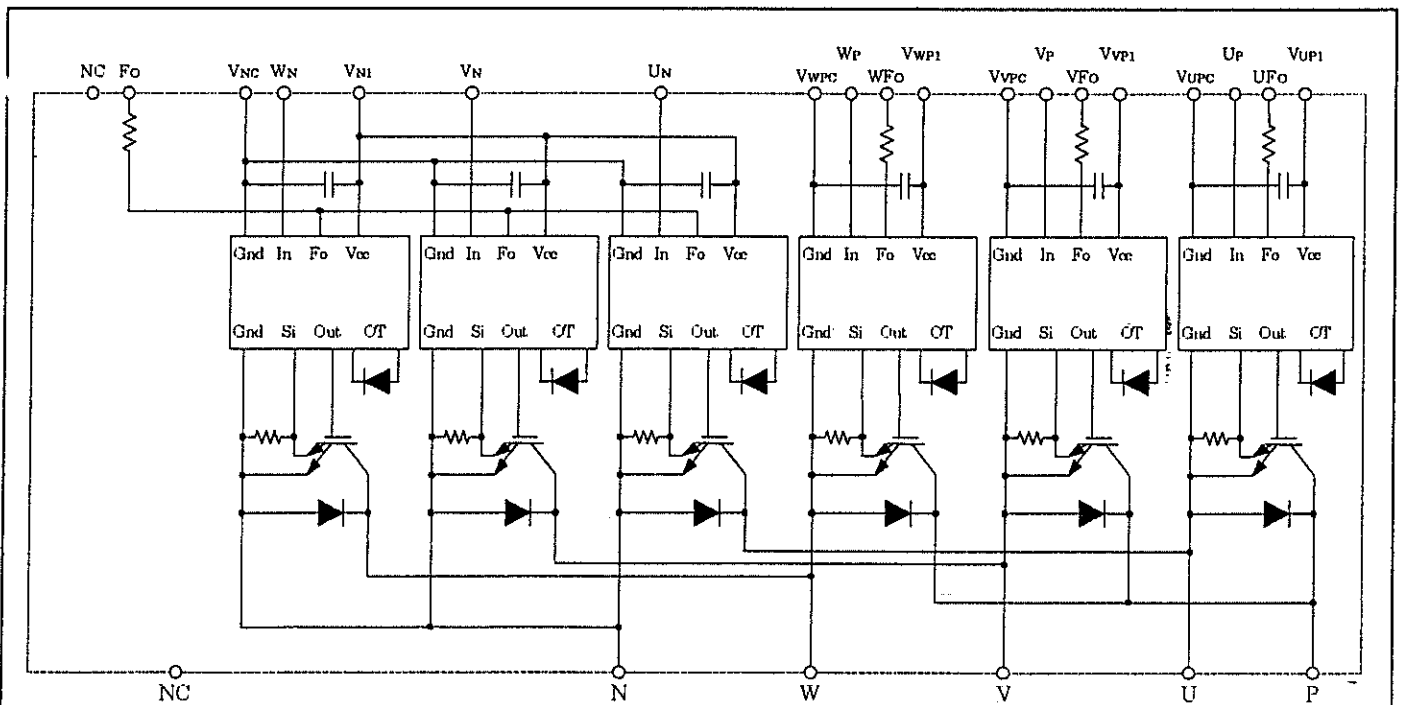

Maximum Ratings (Tj = 25°C , unless otherwise noted)

Inverter Part

Item	Symbol	Condition	Ratings	Unit
Collector-Emitter Voltage	V _{CEs}	V _D = 15V, V _{CIN} = 15V	600	V
Collector Current	±I _C	T _C = 25°C	75	A
Collector Current (Peak)	±I _{CP}	T _C = 25°C	150	A
Collector Dissipation	P _C	T _C = 25°C	416	W
Junction Temperature	T _j		-20 ~ +150	°C

Control Part

Item	Symbol	Condition	Rating	Unit
Supply Voltage	V _D	Applied between : V _{UP1} -V _{UPC} V _{VP1} -V _{VPC} , V _{WN1} -V _{VNC}	20	V
Input Voltage	V _{CIN}	Applied between : U _P -V _{UPC} , V _P -V _{VPC} W _P -V _{WPC} , U _N -V _N -W _N -V _{VNC}	20	V
Fault Output Supply Voltage	V _{FO}	Applied between : U _{FO} -V _{UPC} , V _{FO} -V _{VPC} W _{FO} -V _{WPC} , F _O -V _{VNC}	20	
Fault Output Current	I _{FO}	Sink current at U _{FO} , V _{FO} , W _{FO} , F _O terminals	20	mA

Total System

Item	Symbol	Condition	Rating	Unit
Supply Voltage Protected by SC	V _{CC(prot)}	V _D = 13.5~16.5V Inverter Part, T _j = +125°C Start	400	V
Supply Voltage (Surge)	V _{CC(surge)}	Applied between : P-N, Surge value	500	V
Module Case Operating Temperature	T _C	(Note-1)	-20 ~ +100	°C
Storage Temperature	T _{stg}		-40 ~ +125	°C
Isolation Voltage	Viso	60Hz, Sinusoidal Charged part to Base, AC 1 min.	2500	Vrms

(Note-1) T_C(under the chip) measurement point is below. (unit : mm)

arm axis	UP		VP		WP		UN		VN		WN	
	IGBT	FWDi	IGBT	FWDi	IGBT	FWDi	IGBT	FWDi	IGBT	FWDi	IGBT	FWDi
X	28.7	28.7	65.2	65.2	85.3	85.3	38.0	38.0	55.4	55.4	75.5	75.5
Y	-6.6	0.85	-6.6	2.5	-6.6	2.5	4.6	-4.5	4.6	-4.5	4.6	-4.5

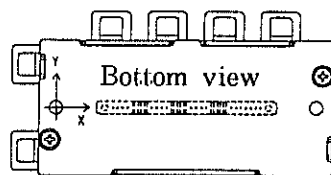

Thermal Resistances

Item	Symbol	Condition	Min.	Typ.	Max.	Unit
Junction to case Thermal Resistances	R _{th(j-c)Q}	Inverter IGBT part (per 1/6) (Note-1)	-	-	0.30*	°C/W
	R _{th(j-c)F}	Inverter FWDi part (per 1/6) (Note-1)	-	-	0.52*	
Contact Thermal Resistance	R _{th(c-f)}	Case to fin, (per 1 module) Thermal grease applied	-	-	**	

* If you use this value, R_{th(f-a)} should be measured just under the chips.

** : This value is not specified yet.

Electrical Characteristics (Tj= 25°C unless otherwise noted)

Inverter Part

Item	Symbol	Condition	Min.	Typ.	Max.	Unit	
Collector-Emitter Saturation Voltage	V _{CE(sat)}	V _D = 15V, V _{CIN} = 0V I _C = 75A, Pulsed Fig.1	Tj = 25°C	—	1.5	2.0	V
			Tj = 125°C	—	1.5	2.0	
FWDi Forward Voltage	V _{EC}	-I _C = 75A, V _{CIN} = 15V V _D = 15V Fig.2	—	2.2	3.3	V	
Switching Time	t _{on}	V _D = 15V, V _{CIN} = 0V ↔ 15V V _{CC} = 300V, I _C = 75A Tj = 125°C, Inductive Load Fig.3	—	0.8	1.2	2.4	μs
	t _{rr}		—	0.15	0.3		
	t _{c(on)}		—	0.4	1.0		
	t _{off}		—	2.0	2.8		
	t _{c(off)}		—	0.6	1.2		
Collector-Emitter Cutoff Current	I _{CES}	V _{CE} = V _{CES} V _D = 15V Fig.4	Tj = 25°C	—	—	1	mA
			Tj = 125°C	—	—	10	

Control Part

Item	Symbol	Condition	Min.	Typ.	Max.	Unit	
Circuit Current	I _D	V _D = 15V V _{CIN} = 15V	V _{N1} -V _{NC}	—	20	30	mA
			V _{XPI} -V _{XPC}	—	6	10	
Input ON Threshold Voltage	V _{ih(ON)}	Applied between : U _P -V _{UPC} , V _P -V _{VPC}	1.2	1.5	1.8	V	
Input OFF Threshold Voltage	V _{ih(OFF)}	W _P -V _{WPC} , U _N -V _N -W _N -V _{NC}	1.7	2.0	2.3	V	
Short Circuit Trip Level	SC	-20 ≤ Tj ≤ 125°C Fig.5,6 V _D = 15V Fig.5,6	150	241	—	A	
Short Circuit Current Delay Time	t _{off(SC)}	V _D = 15V Fig.5,6	—	10	—	μs	
Over Temperature Protection	OT	Detect Tj of IGBT chip	Trip level	135	145	155	°C
	OTr		Reset level	—	125	—	
Supply Circuit Under-Voltage Protection	UV	-20 ≤ Tj ≤ 125°C	Trip level	11.5	12.0	12.5	V
	UVr		Reset level	—	12.5	—	
Fault Output Current	I _{FO(H)}	V _D = 15V, V _{CIN} = 15V (Note-2)	—	—	0.01	mA	
	I _{FO(L)}		—	10	15		
Minimum Fault Output Pulse Width	t _{FO}	V _D = 15V (Note-2)	1.0	1.8	—	ms	

(Note-2) Fault output is given only when the internal SC, OT & UV protections schemes of either upper or lower arm device operate to protect it.

Mechanical Ratings and characteristics

Item	Symbol	Condition	Min.	Typ.	Max.	Unit
Mounting torque	—	Main terminal screw : M 5	2.5	3.0	3.5	N · m
Mounting torque	—	Mounting part screw : M 5	2.5	3.0	3.5	N · m
Weight	—	—	—	300	—	g

Recommended Conditions For Use

Item	Symbol	Condition	Recommended value	Unit
Supply Voltage	V_{CC}	Applied across P-N terminals	≤ 400	V
Control Supply Voltage	V_D	Applied between : $V_{UP1}-V_{UPC}$ $V_{VP1}-V_{VPC}$, $V_{WP1}-V_{WPC}$, $V_{UN1}-V_{UNC}$ (Note-3)	15.0 ± 1.5	V
Input ON Voltage	$V_{CIN(ON)}$	Applied between : U_P-V_{UPC} , V_P-V_{VPC} W_P-V_{WPC} , $U_N \cdot V_N \cdot W_N-V_{NC}$	≤ 0.8	V
Input OFF Voltage	$V_{CIN(OFF)}$		≥ 4.0	
PWM Input Frequency	f_{PWM}	Using Application Circuit of Fig.8	≤ 20	kHz
Arm Shoot-through Blocking Time	t_{dead}	For IPM's each input signals Fig.7	≥ 2.0	μ s

(Note-3) With ripple satisfying the following conditions
 dv/dt swing $\leq \pm 5V/\mu s$, Variation $\leq 2V$ peak to peak

Precautions for testing

1. Before applying any control supply voltage (V_D), the input terminals should be pulled up by resistores, etc. to their corresponding supply voltage and each input signal should be kept off state. After this, the specified ON and OFF level setting for each input signal should be done.
2. When performing "SC" tests, the turn-off surge voltage spike at the corresponding protection operation should not be allowed to rise above V_{CES} rating of the device.
 (These test should not be done by using a curve tracer or its equivalent.)

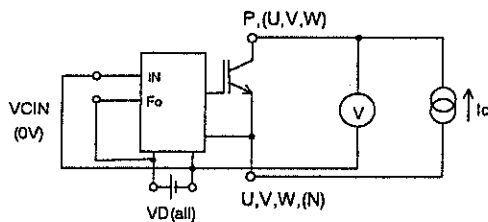

Fig.1 $V_{CE(sat)}$ Tset

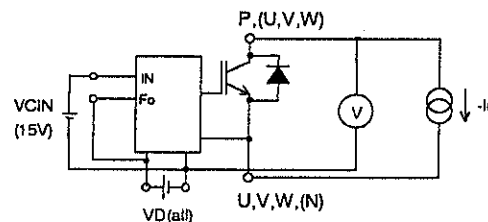

Fig.2 V_{EC} Tset

PM75CLA060

FLAT-BASE TYPE
INSULATED PACKAGE

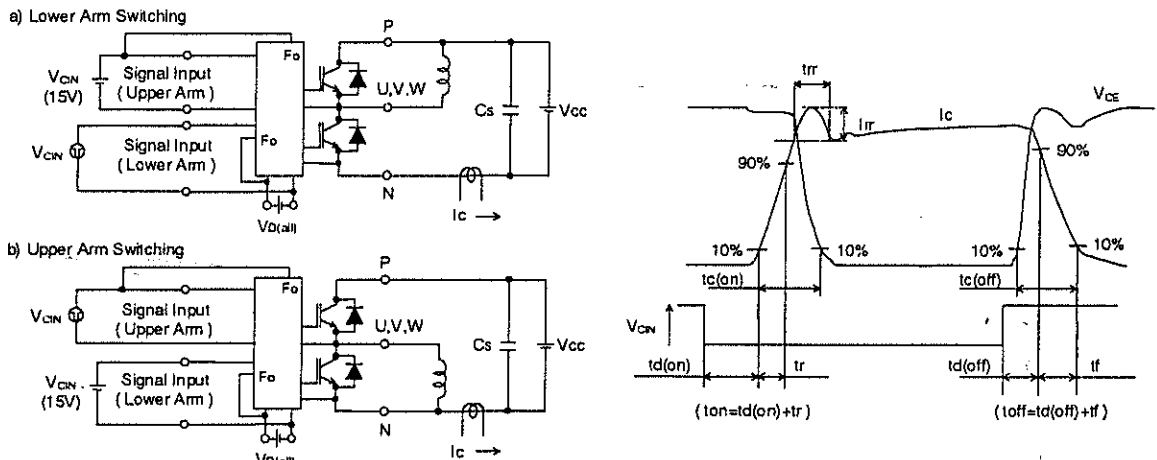

Fig.3 Switching time test circuit and waveform

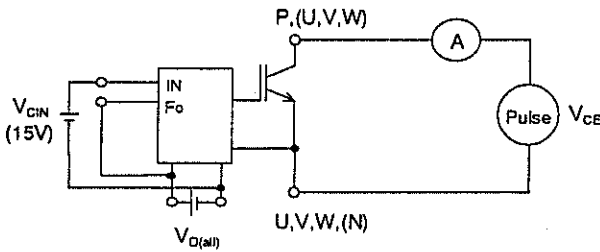

Fig.4 ICES Test

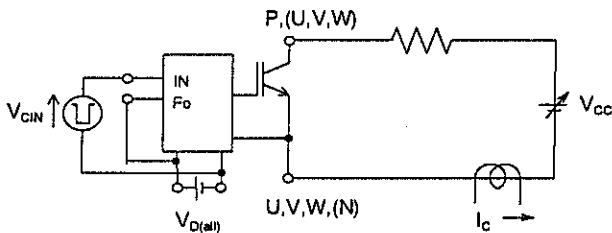

Fig.5 SC Test

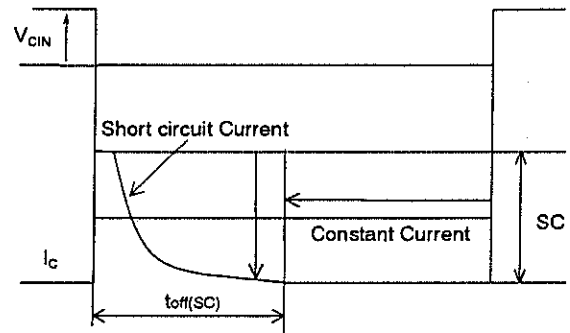
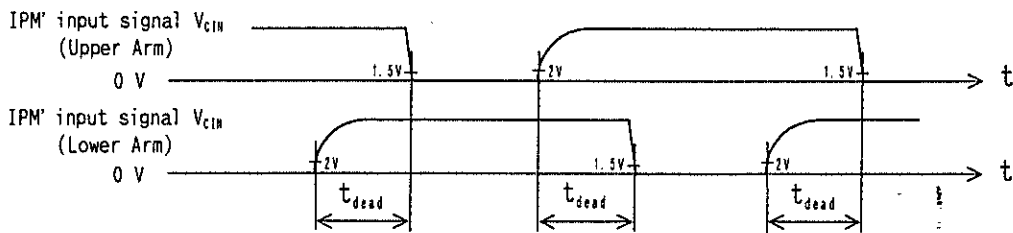

Fig.6 SC Test waveform



1.5V: Input on threshold voltage $V_{th(on)}$ typical value, 2V: Input off threshold voltage $V_{th(off)}$ typical value

Fig.7 Dead time measurement point example

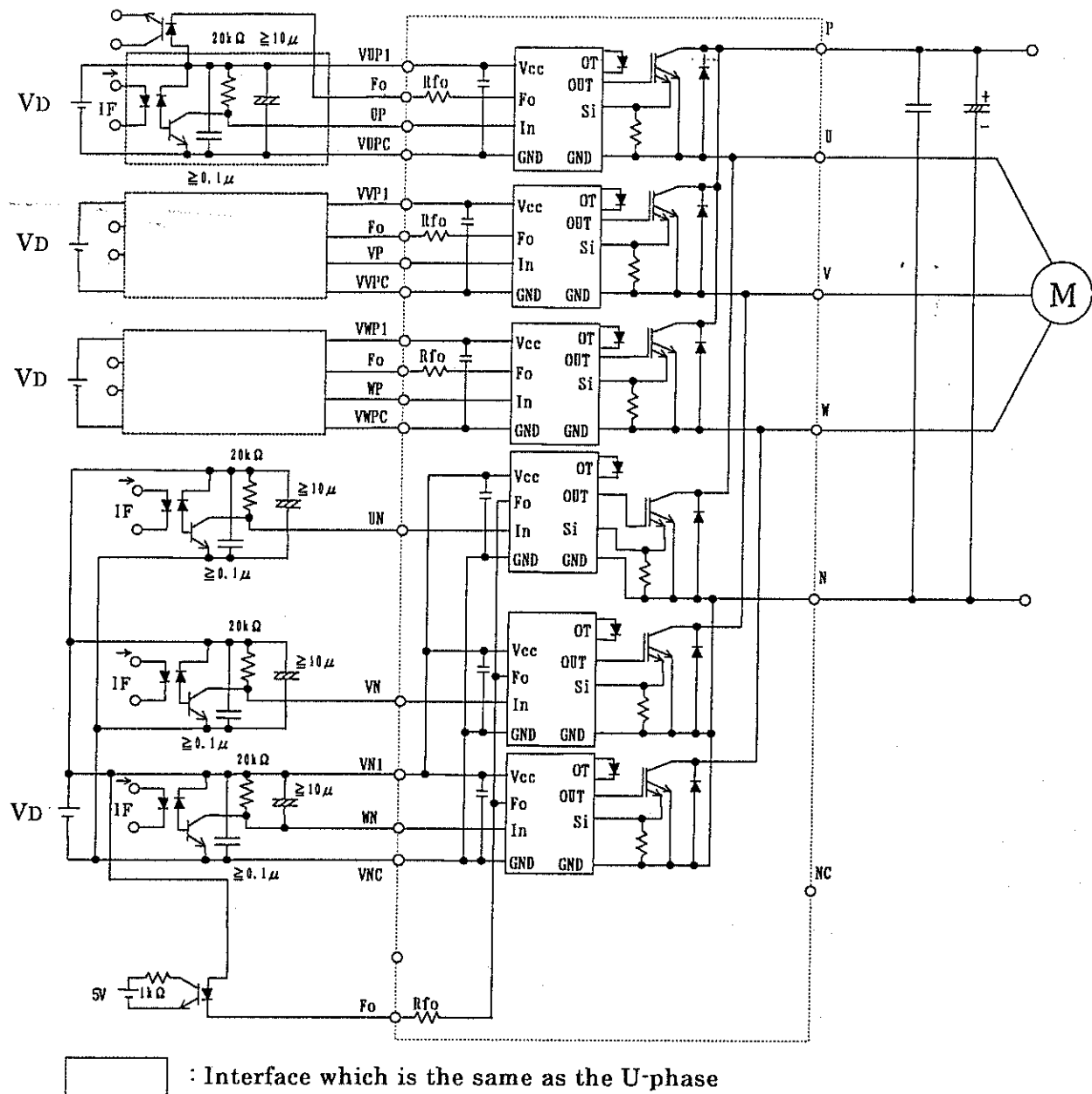

Fig. 8 Application Example Circuit

Notes for stable and safe operation :

- Design the PCB pattern to minimize wiring length between opto-coupler and IPM's input terminal, and also to minimize the stray capacity between the input and output wirings of opto-coupler.
- Connect low impedance capacitor between the Vcc and GND terminal of each fast switching opto-coupler.
- Fast switching opto-couplers : $t_{PLH}, t_{PHL} \leq 0.8 \mu s$, Use High CMR type.
- Slow switching opto-coupler : $CTR > 100\%$
- Use 4 isolated control power supplies (V_D). Also, care should be taken to minimize the instantaneous voltage charge of the power supply.
- Make inductance of DC bus line as small as possible, and minimize surge voltage using snubber capacitor between P and N terminal.
- Use line noise filter capacitor (ex. 4.7nF) between each input AC line and ground to reject common-mode noise from AC line and improve noise immunity of the system.

Outline drawings

[Dimensions in mm]

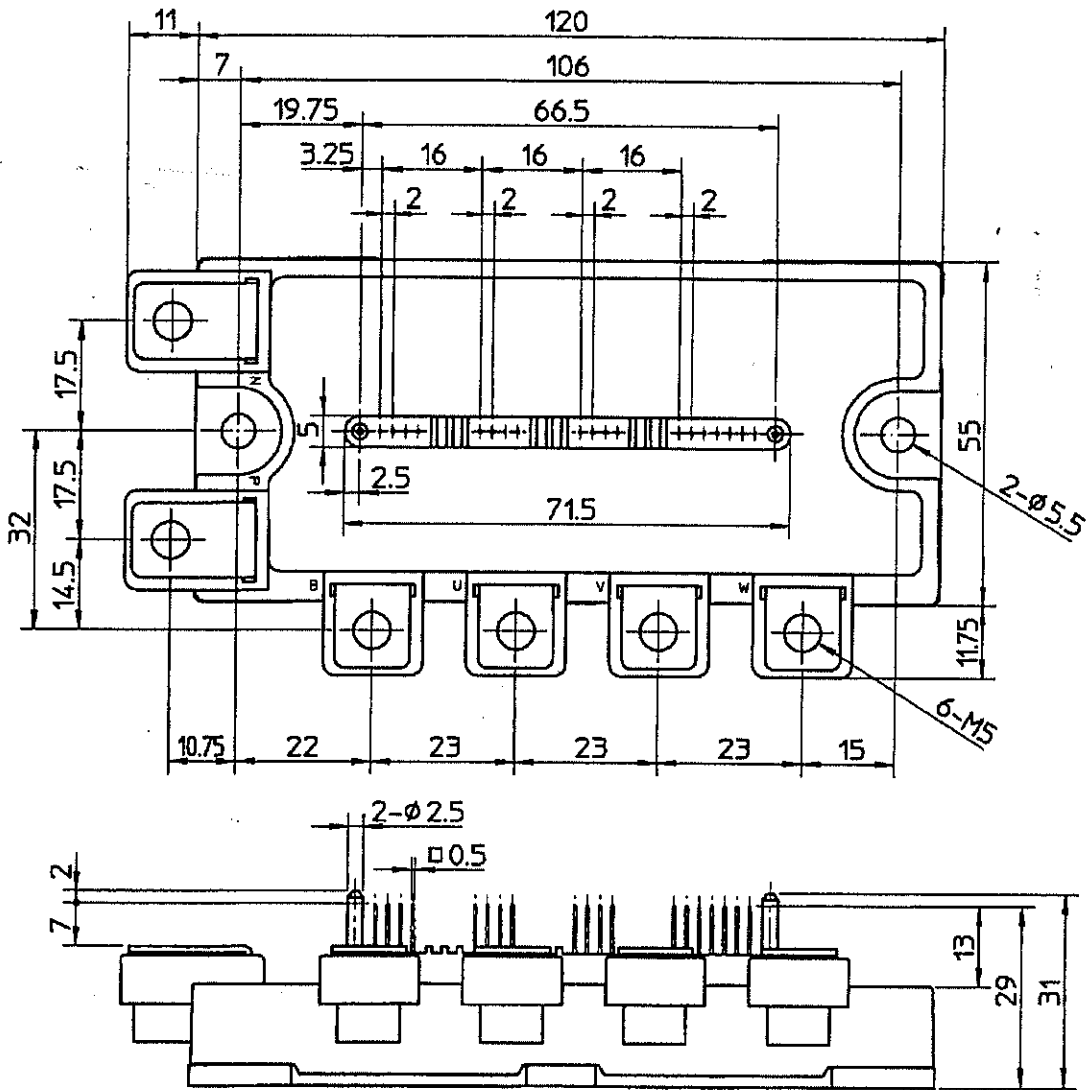

Terminal code

1. VUPC	6. VFO	11. WP	16. UN
2. UFO	7. VP	12. VWP1	17. VN
3. UP	8. VVP1	13. VNC	18. WN
4. VUP1	9. VWPC	14. VN1	19. Fo
5. VVPC	10. WFO	15. NC	

